



Operating Instructions

ELECTRIC STEP



www.amf-bruns.de

Foreword

Dear reader,

These Operating Instructions serve to provide all information required for the safe use of the Electric Step.

The Electric Step is designed and constructed in accordance with state of the art technology and recognised safety standards. Persons and materials can however be endangered, as not all danger areas can be eliminated if the functional capability is to be maintained. Accidents caused by these dangers can however be prevented by strictly observing these Operating Instructions.

These Operating Instructions only apply to the Electric Step specified on the cover page and in the footnotes. Please check these details against those on the rating plate.

After reading these Operating Instructions for the first time, keep them in a safe place for future reference over the entire lifetime of the Electric Step. If you sell the Electric Step, hand these Operating Instructions over to the new owner.

All details, figures and dimensions contained in these Operating Instructions are without obligation. No claims in any form can be derived from these.

This document must not be reproduced or duplicated, in full or in part, without the prior, written permission of the manufacturer.

The Electric Step must never be converted or modified in any way, without seeking the prior, written permission of the manufacturer. The manufacturer will not be held responsible in any way whatsoever if conversions or modifications are carried out without authorisation.

Use only original spare parts or spare parts which have been approved of by the manufacturer. If spare parts other than these are used, this can have a negative effect on the specified characteristics, the functionality and safety of the Electric Step. Using non-original or unauthorised spare parts will render the guarantee null and void.

Contact our customer services department to order spare parts or accessories (see Chapter 10, page 25).

Explanation of symbols and signs

To improve understanding, the following conventions should be met for these Operating Instructions:

1.

The following types of special note are used to highlight text passages of an important nature.



DANGER!

- warns of a situation of immediate danger, which will lead to serious or fatal injuries, if not avoided.



WARNING!

- warns of a potentially dangerous situation, which will lead to serious or fatal injuries, if not avoided.



CAUTION!

- warns of a potentially dangerous situation, which will lead to slight or minor injuries, or material damage if not avoided.



ATTENTION!

...warns of a potentially dangerous situation, which can cause material damage, if not avoided.



...contains general notes and useful information.



...gives a reference to important information in other sections and documents.

2.

Some texts serve a particular purpose. These are identified as follows:

- Lists
- ⇒ Instructional text, e.g. a sequence of activities.

Contents

Foreword	3
Contents	5
1 Safety	7
1.1 Proper Use	8
1.2 Improper Use.....	8
1.3 Requirements of the User	9
1.4 Product Monitoring	9
1.5 Danger Zone.....	10
1.6 Safety Devices	10
1.6.1 Electric motor current limiting	10
1.6.2 Signalling system	10
1.7 Safety and Accident Prevention Regulations	11
1.8 Disposal	12
2 Description	13
2.1 Step Tread	13
2.2 Frame	14
2.3 Motor.....	14
2.4 Rating Plate	14
2.5 Operating Controls.....	15
2.6 Technical Data	15
3 Transportation	16
4 Installation / Commissioning	17
5 Operation	18
5.1 Safety Regulations for Operation	18
5.2 Manual Operation	19
5.3 Automatic Operation.....	19
6 Maintenance and Repair	20
6.1 Safety Regulations for Maintenance and Repair	20
6.2 Routine Maintenance Work.....	21
6.2.1 Maintenance schedule	21
6.2.2 Maintenance records	21
6.3 Cleaning.....	21
6.4 Maintenance and Inspection Record	22

7	De-Commissioning and Conservation	23
8	Faults and Troubleshooting	23
9	Electrical Circuit Diagram	24
10	Customer Service	25
11	Declaration of Conformity.....	26

1 Safety

CAUTION!

There are a number of risks of suffering personal injury and material damage involved in the operation and maintenance of the Electric Step.



Therefore:

- It is imperative, that these Operating Instructions are read thoroughly before operating your Electric Step. Always observe the notes and information contained therein, in particular the safety instructions.
 - If these Operating Instructions or parts thereof are lost or become illegible, please request a new copy from the manufacturer.
-

Prerequisite to the safe handling and trouble-free operation of the Electric Step is a thorough knowledge of the applicable safety information and the safety regulations.

It is therefore imperative that this Chapter is read thoroughly before operating the Electric Step and that the instructions and warnings herein are strictly observed. The safety information and warnings, given at the appropriate places in the following Chapters, must also be strictly observed. The manufacturer will not be held responsible if safety information and warnings are not observed.

In addition to the information given in these Operating Instructions, local legislative regulations must be taken into consideration, in particular those regarding safety and accident prevention.

1.1 Proper Use

The Electric Step is used to assist persons in boarding or alighting from a vehicle.

Proper use also includes strictly adhering to the information given in these Operating Instructions.

WARNING!

If the Electric Step is used for any other purpose than that described above, this can create dangerous situations for persons or cause material damage.

Therefore:

- Only use the Electric Step for the purpose for which it was intended.
 - Always adhere to information given in these Operating Instructions.
 - Do not use the Electric Step for any other purpose, particularly those given in Section 1.2. These are deemed to be improper use.
-



1.2 Improper Use

Any type of use, other than that mentioned in section 1.1 is deemed to be improper use.

The Electric Step is deemed to be improperly used if for example:

- it is used to deposit goods on when loading or unloading the vehicle,
- it is subject to loads in excess of 150 kg,
- it is operated by persons who do not fulfil the necessary requirements (see Section 1.3, page 9).

1.3 Requirements of the User

The Electric Step is only allowed to be used and operated by the following persons:

- The driver of the vehicle, who has read these Operating Instructions.
- Other persons, who have read these Operating Instructions.
- Other persons who have been made aware of the Electric Step and its function by the driver of the vehicle.

Transportation, installation, commissioning, maintenance, repair, fault finding and disposal of the Electric Step must only be carried out by persons with the corresponding technical training and experience.

1.4 Product Monitoring

Please contact AMF-Brunns GmbH & Co. KG immediately if faults or problems are encountered when operating your Electric Step or if accidents or "near-misses" occur.

AMF-Brunns will effect a solution to the problem with your help and the knowledge gained will flow into future projects.

NOTE

Guarantee work on the Electric Step must only be carried out with the prior agreement of AMF-Brunns GmbH & Co. KG.

The costs of such work will not be accepted by AMF-Brunns without prior agreement.



1.5 Danger Zone

Persons standing within the danger zone can be at risk of injury.

The danger zone is the area in the immediate vicinity of the vehicle, where the step extends. When the step is being extended or retracted, the area on the door sill also forms part of the danger zone.

CAUTION!

Risk of injury through movements of the Electric Step.

There is a risk of sustaining injuries if standing within the danger zone.



Therefore:

- Stand at a safe distance from the vehicle when the step is being extended.
- If necessary, inform other persons of the danger.
- Make certain that nobody is standing on the step when it is being extended or retracted.

1.6 Safety Devices

1.6.1 Electric motor current limiting

With an Electric Step in the automatic mode the control unit is equipped with a current limiter. This limits the current supplied to the motor. This reduces the force at which the step will hit an obstacle when being extended.

This current limiter prevents persons, who are standing too close to the vehicle, from being injured by the step when it is being extended.

1.6.2 Signalling system

An acoustic warning signal sounds when the step is being extended. The warning signal sounds until the step has been fully retracted.

1.7 Safety and Accident Prevention Regulations

Adhere to the following notes in order to prevent personal injuries and material damage.

- Safety and protective devices (see Section 1.6, page 10) must only be removed to carry out maintenance and repair work. All safety and protective devices must be replaced immediately after such work has been completed. If they are not replaced correctly, there is a high risk of injury.
- The Electric Step must only be used for the purpose for which it is intended, otherwise dangerous situations, with resultant injuries, may occur (Proper Use: see Section 1.1, page 8).
- Proper use of the Electric Step also includes adherence to the specified maintenance and repair work, in particular strict adherence to the maintenance intervals (see Chapter 6, page 20). If such work is not carried out, trouble-free operation can not be guaranteed. Risks of personal injury and material damage can occur.
- Upon completion of installation, the Electrical Step must be inspected by a technical expert. During inspection, faults affecting the safety should be systematically identified and remedial action taken.
- If modifications are made to the construction or major repair has been carried out on load bearing parts of the step, these must also be inspected by a technical expert.
- The Electric Step must not be operated in a faulty condition, as serious injuries may be caused by this. If faults occur, initiate repairs.
- Do not place any objects on the step. Persons can suffer injury if these fall off.
- Switch the Electric Step OFF before carrying out maintenance and repair work. This includes cleaning work. Make certain that no other person can switch the Electric Step ON (e.g. by disconnecting the vehicle's battery). If this is not done, there is a risk of injury.
- Use only original spare parts or spare parts which have been approved of by the manufacturer. If non-original or unauthorised replacement parts are used, this will render the guarantee null and void.

1.8 Disposal

When the Electric Step's useful life has expired, it must only be disposed of by qualified specialists. The manufacturer will accept no liability for damage caused by incorrect disposal.

2 Description

Persons enter or leave a vehicle by means of the Electric Step.

The main components of the Electric Step are:

- the step tread,
- the frame and
- the motor.

The aim of this chapter is to illustrate the construction and function of the Electric Step. To this end, the individual assemblies and components are described in the following sections.

2.1 Step Tread

The step tread automatically extends when the side door is opened or by operating a rocker switch. When the vehicle is in motion, it is retracted under the vehicle. The step tread has a non-slip surface. To increase the safety, it has rounded plastic corners of a signal yellow colour (see Figure 1).



Step tread

Figure 1: Step Tread

2.2 Frame

The frame is a steel construction that is bolted to the underside of the vehicle (see Figure 2). It comprises a fixed part and two extendible, square guide tubes that are connected to the step tread.

2.3 Motor

The Electric Step's drive motor is a 12 V DC motor that extends and retracts the tread step by means of a linear drive (see Figure 2).

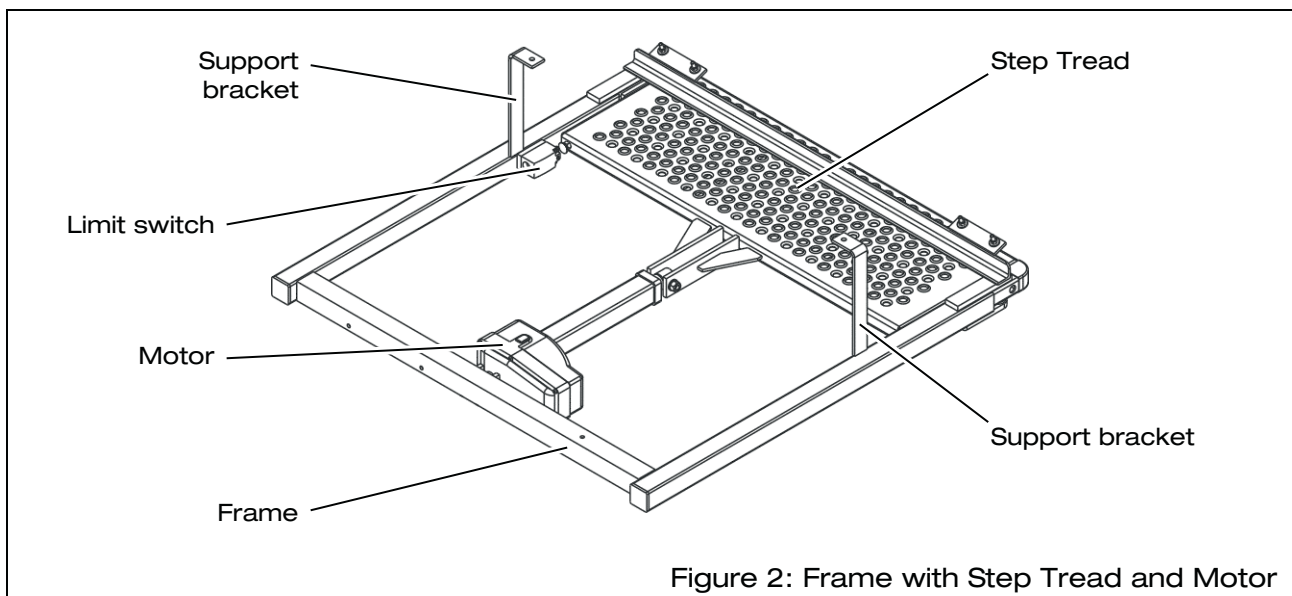

Figure 2: Frame with Step Tread and Motor

2.4 Rating Plate

A rating plate, which contains the fundamental data, is attached to the Electric Step (see Figure 3). The rating plate is located on the front edge of the step tread.

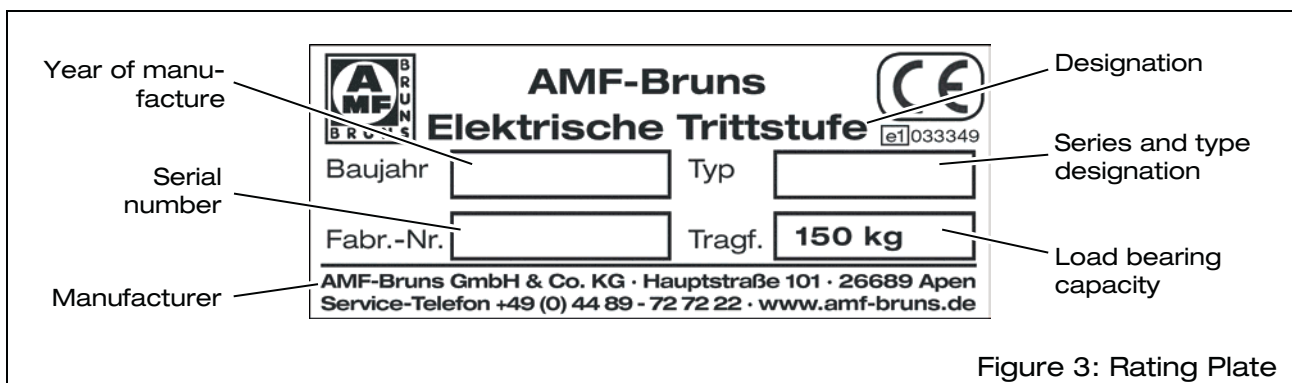

Figure 3: Rating Plate

2.5 Operating Controls

Rocker switch

The Electric Step is extended or retracted by operating the rocker switch. It is only available with a manually operated Electric Step.

The rocker switch is installed on the B-column. When the side door is closed, the rocker switch is concealed. This is to prevent it from being operated inadvertently.

2.6 Technical Data

Designation	Electric Step
Weight	22 kg
Tread depth	290 mm
Tread width	810 mm
Overall width	900 mm
Permissible number of persons allowed on the step tread	max. 1 person
Maximum load bearing capacity	150 kg
Extend time	approx. 4 seconds
Retract time	approx. 4 seconds
Extend retract drive	12 V DC linear drive
Sound pressure emission	< 70 dB(A)
Equipment suitable for use	outdoors
Rated current	14 A
Electrical power	0.17 kW

3 Transportation



CAUTION!

Dangers involved in the transportation of the Electric Step.

The Electric Step can fall over or fall down during transportation. There is a risk of personal injury or material damage.

Therefore:

- Proceed with caution when transporting the Electric Step.
-
-



NOTE

AMF-Brunns GmbH will accept no liability whatsoever for damage caused due to improper transportation.

4 Installation / Commissioning



The Electric Step must be installed in accordance with the AMF-Bruns Installation Instructions applicable to the vehicle in question.

DANGER!

Risk of danger through incorrect installation.

A number of risks of personal injury and material damage can be caused if the Electric Step is incorrectly installed in the vehicle.

Such risks of danger can not only occur during installation but also as a result of installation not being carried out correctly.

Therefore:

- The Electric Step must only be installed by trained, specialist personnel. This also applies to the electrical connections.
 - The vehicle manufacturer's body fitting guidelines must be adhered to.
 - A technical expert must be called in to inspect that installation has been carried out correctly and that the safety devices are effective.
 - The Electric Step must not be used until this has been done.
-



5 Operation

5.1 Safety Regulations for Operation



Before operation, read the notes in Chapter “Safety Information” (see Chapter 1, page 7).



DANGER!

Risk of injury and material damage the vehicle is in motion.

If the Electric Step extends when the vehicle is in motion, there is the risk of other road users suffering seriously injuries. Material damage can be caused.

Therefore:

- Always check that the Electric Step is retracted before setting off on a journey.
-
-



WARNING!

Risk of injury through a defective Electric Step.

If the Electric Step is damaged or if its fastenings have come loose, this can cause accidents.

Therefore:

- Check the Electric Step at regular intervals for damage and loose fastenings.
 - Load the Electric Step with a maximum of 150 kg.
-
-



CAUTION!

Risk of injuries through falling or crushing.

If persons stand on the step tread when it is being extended or retracted, there is a risk of injury through falling or crushing between the step tread and the vehicle.

Therefore:

- No persons must stand on the step tread when it is being extended or retracted.
-
-



CAUTION!

Risk of injury through being hit.

If persons stand too close to the vehicle when the Electric Step is being extended, there is a risk of injury by being hit.

Therefore:

- Stand a safe distance from the vehicle.
 - If necessary, make other persons aware of the extending Electric Step.
-

5.2 Manual Operation

- ⇒ Open the side door of the vehicle.
- ⇒ Press and hold the lower half of the rocker switch, until the Electric Step has fully extended.

After entering or leaving the vehicle:

- ⇒ Press and hold the upper half of the rocker switch, until the Electric Step has fully retracted.

5.3 Automatic Operation

An Electric Step with automatic operation is directly connected to a door contact switch on the side door. When the side door is opened, the Electric Step automatically extends. When the side door is closed, the Electric Step automatically retracts.

There is no rocker switch or other controls available.

6 Maintenance and Repair

6.1 Safety Regulations for Maintenance and Repair



Read the "Safety" Chapter before carrying out maintenance and repair work (see Chapter 1, page 7).

WARNING!

Risk of injury if protective and safety devices are removed or are defective.

If protective and safety devices are removed, they will no longer fulfil their function.

Therefore:

- Always refit protective and safety devices if they have been removed (e. g. for maintenance or repair purposes).
 - Never modify, bypass or remove protective and safety devices.
-



WARNING!

Risk of injury and material damage if maintenance and repair work is not carried out correctly.

Therefore:

- only allow specialist personnel to carry out maintenance and repair work.
 - if repair work has been carried out on load bearing parts, this must be inspected by a technical expert.
-



WARNING!

Risk of personal injury or material damage if inferior quality spare parts are used.

The manufacturer will accept no liability whatsoever for damage or injury caused by the use of non-original spare parts or spare parts that have not been approved of by the manufacturer.

Therefore:

- use only original spare parts or spare parts that have been approved of by the manufacturer.
-



6.2 Routine Maintenance Work

The maintenance schedule below lists the maintenance work that must be carried out at regular intervals.

Contact the customer service department for maintenance work that must be carried out by a specialist (see Chapter 10, page 25).

6.2.1 Maintenance schedule

Interval	Activity	see
before use	Check for damage and unusual operating noises. Initiate repairs if necessary.	
quarterly	Clean the Electric Step.	Section 6.3
yearly	Test the function of safety devices.	Section 1.6
	Check that all fastenings are secure.	

6.2.2 Maintenance records

Enter maintenance and repair work that has been carried out into the maintenance record foreseen for this purpose (see Section 6.4, page 22). This provides a traceable record of maintenance work.

For records of maintenance work over and above this, it is recommended that you keep your own lists.

6.3 Cleaning

Depending upon the degree of dirt, clean the Electric Step at intervals of three months:

- ⇒ Remove the bolt on the piston rod of the motor using an SW 17 spanner.
- ⇒ Pull the step tread out by hand.
- ⇒ Click the end caps underneath the step out using a screwdriver.
- ⇒ Clean the inner guide tubes. Do not grease the components.
- ⇒ Re-assemble the Electrical Step in the reverse order.

6.4 Maintenance and Inspection Record

Maintenance work carried out		
Date	Signature	Remarks / work carried out

7 De-Commissioning and Conservation

For queries regarding de-commissioning and conservation, contact our customer services department (see Chapter 10, page 25).

8 Faults and Troubleshooting



WARNING!

Risk of injury and material damage if repair work is carried out incorrectly.

Therefore:

- Only allow specialist personnel to carry out repair work.

If faults occur when operating the Electric Step, proceed as described in the following troubleshooting table. Contact the customer service department if faults are encountered which cannot be remedied using the information and measures given.

Fault	(possible) Cause	Remedial Measures
The step tread does not move	The vehicle's battery is discharged.	Charge the vehicle's battery.
	The fuse has blown.	Replace the Electric Step's blown fuse (location: in the vicinity of the battery).
	The rocker switch (for manual operation) or the door contact switch (for automatic operation) is defective.	Check the rocker switch or door contact switch and replace it if necessary.
	The electric motor's current limiter needs adjusting or is defective.	Have the current limiter re-adjusted in a specialist workshop.
	The electric motor is defective.	Check the electric motor and replace it if necessary.
	The cable harness is defective.	Check the cable harness and repair as necessary.

9 Electrical Circuit Diagram

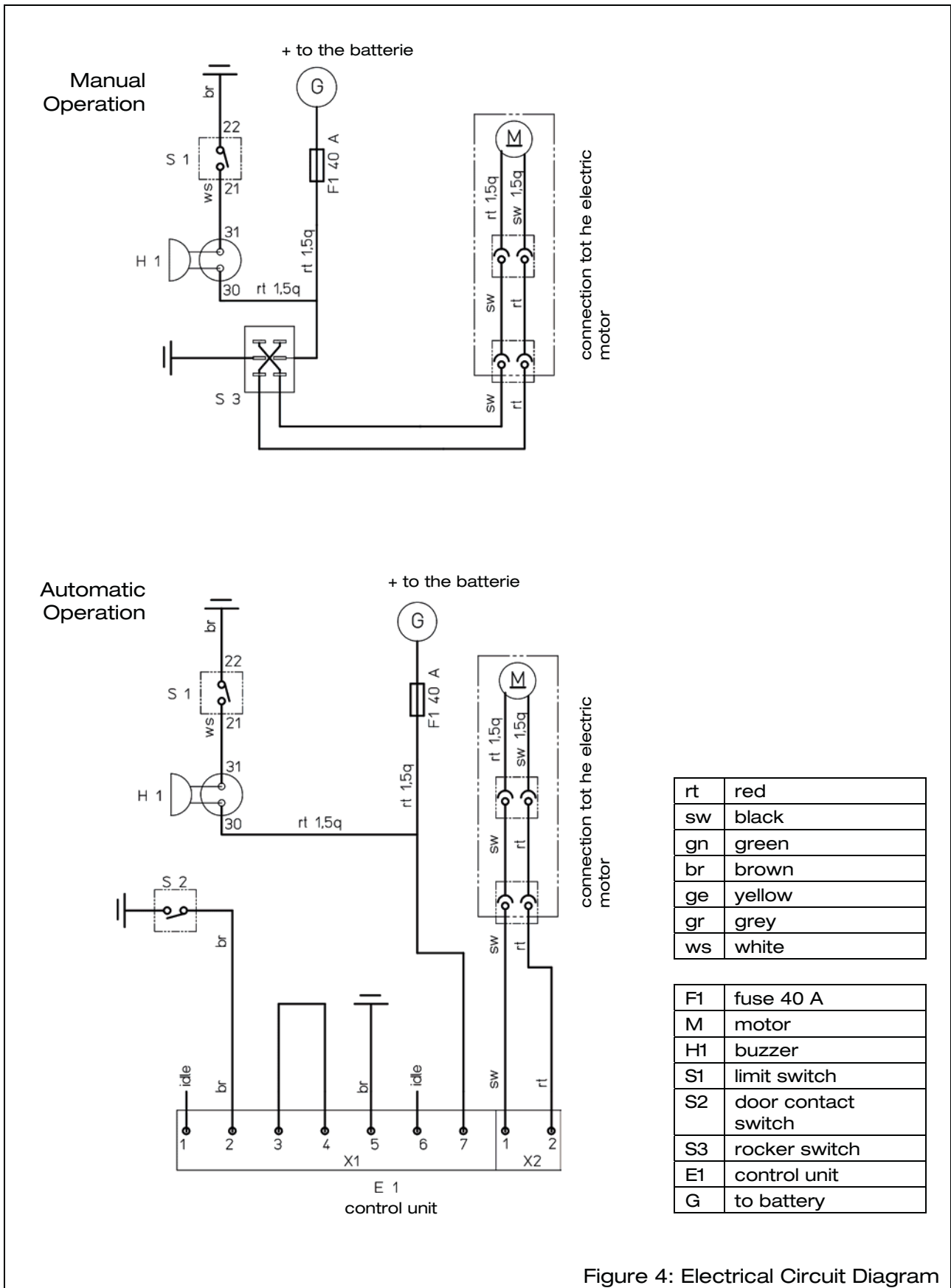

Figure 4: Electrical Circuit Diagram

10 Customer Service

The AMF-Bruns customer service department will be more than pleased to assist in ordering spare parts, maintenance and repair work and help with general problems or queries.

The address is:

AMF-Bruns GmbH & Co. KG
Hauptstraße 101
D - 26689 Apen

Tel.: +49 (0) 44 89 / 72 72-30

Fax: +49 (0) 44 89 / 62 45

service.hubmatik@amf-bruns.de

www.amf-bruns.de



NOTE

Guarantee work on the Electric Step must only be carried out with the prior agreement of AMF-Bruns GmbH & Co. KG.

The costs of such work will not be accepted by AMF-Bruns without prior agreement.

11 Declaration of Conformity



EC - Declaration of Conformity

In accordance with the EC Machinery Directive 2006/42/EC, Appendix II A

We, the manufacturer, declare that the below mentioned, machine complies with the fundamental health and safety requirements of EC Directive 2006/42/EC in its conception and design as well as in the version introduced to the market by us. This declaration will be rendered null and void if alterations are made to the machine without our consent.

Designation: **Electric Step**

Type: see rating plate

Serial number: see rating plate

Manufacturer:

Company: **AMF-Brunns GmbH & Co. KG**

Address: **Hauptstraße 101
26689 Apen**

Harmonised standards applied:

DIN EN ISO 12100

Other technical standards and specifications applied:

DIN 75078-1

Authorised agent for the technical documentation:

Thomas Lakewand (address: see manufacturer's address)

Apen, 01.02.2013

Place, date



Signature

Gerit Bruns, managing director

Details of signatory



AMF-Bruns GmbH & Co. KG | Hauptstraße 101 | 26689 Apen
Telephone +49 (0) 4489 / 72 72 30 | Fax +49 (0) 4489 / 62 45
service.hubmatik@amf-bruns.de

www.amf-bruns.de



Reg.-No. Q1 0105027